

TECHNICAL CHARACTERISTICS

TMIBU

# Mibu

## Stool

In the apparent simplicity of the Mibu stool, a myriad of nuances are hidden. Inspired by the connections between East and the West, this wooden chair merges Japanese influence with the contemporary aesthetics. With clean and pure lines, this piece combines functionality and design.

DESIGNED BY NADIA ARRATIBEL



**ondarreta**

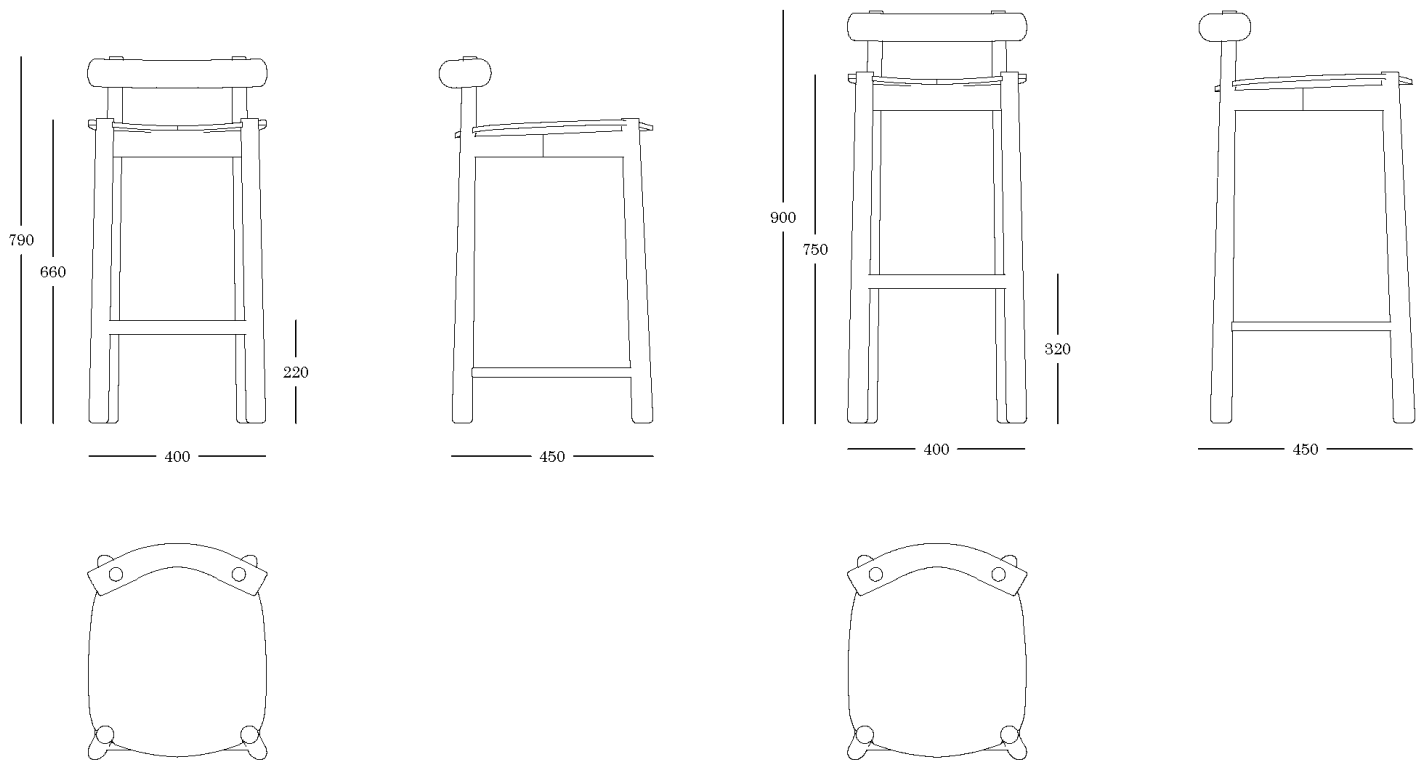

### DIMENSIONS

40 cm x 45 cm x 90 cm x 75 x 33 cm [width x depth x height x seat height x footrest height]

### WEIGHT

5,6 kg (12,35 lb)

### PACKAGING

55,3 cm x 41 cm x 98,5 cm  
(21,8" x 16,1" x 38,8")

### CERTIFICATION

Product tested under the European standard EN 16139:2013, category of extreme use L2.

Designed in accordance with the Ecodesign standard UNE-EN ISO 14006: 2011 certified by AENOR

### ACCESORIES

Felt glides

### ORIGIN

100% Made in Europe

### DESIGN

Nadia Arratibel



## COMPONENTS

### **FRAME**

#### **Material**

Solid Ash wood bowed with a singular method and CNC machined. Backrest is curved by special vaporizing process, pressed and mechanized.

#### **Technical characteristics:**

Medium density: 660 kg/m<sup>3</sup> ; Flex Strength: 1130 kg/cm<sup>2</sup>;  
Tensile Strength: 1450 kg/cm<sup>2</sup>

#### **Finish**

Stained

Footrest protection in stainless steel.

### **BACKREST**

Backrest is curved by special vaporizing process, pressed and mechanized.

#### **Technical characteristics:**

Medium density: 660 kg/m<sup>3</sup>; Flex Strength: 1130 kg/cm<sup>2</sup>;  
Tensile Strength: 1450 kg/cm<sup>2</sup>

#### **Finish**

Stained

### **SEAT**

#### **Ash**

Ash plywood board shell, 10 mm (0.4") thick. It's made with nine especially treated sheets, glued, pressed and CNC machined.

#### **Fabrics**

8 mm (0.31") thick Beech plywood board shell. Medium density polyether stuffing foam.

#### **Technical characteristics:**

Urea-formol glue: low formaldehyde emission (E1 European Normative)

The wood has the PEFC certificate.

#### **Finish**

Stained or upholstered.

## WOOD FINISHES

### **STAIN**

Pigmented enamel with a transparent stain coating. Reactive drying paints: excellent adherence between layers and better mechanical resistance.

#### **Technical characteristics:**

Satisfying UNE-EN 71-3 normative; Formaldehyde free compounds.

## COM REQUIREMENTS

Upholstered seat: 55 cm